

## Data sheet

# 2 - way valve VS 2

### Description / Application



The valves with split or linear characteristic provide a quality, cost effective solution for most LPHW and chilled water applications. These valves may be used with glycol concentrations of up to 30% .

#### Main data:

- SPLIT or LIN characteristic
- Ext. thread PN 16
- Suitable for use with AMV(E) 10/20/30, AMV(E) 13/23/33 and AMV 100 (only DN 15) actuators

Type	AMV 100	AMV 10/13	AMV(E) 10/13	AMV(E) 20/23	AMV(E) 30/33
VS2 DN 15 *	•	•	-	-	-
VS2 DN 20	-	-	•	•	•
VS2 DN 25	-	-	•	•	•

\* VS2 DN 15 valve has linear characteristic and cannot be recommended to be used with modulating controlled actuators (AME actuators) for DHW production.

### Principles

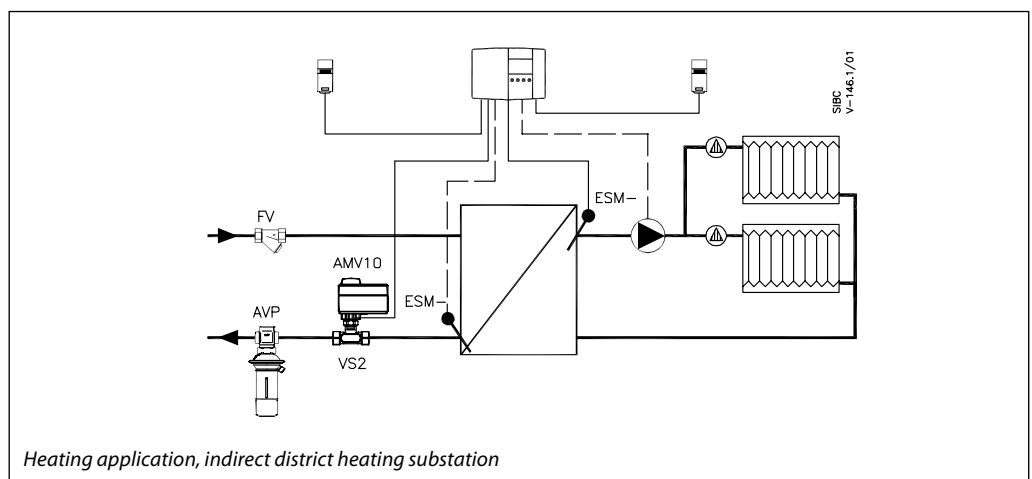
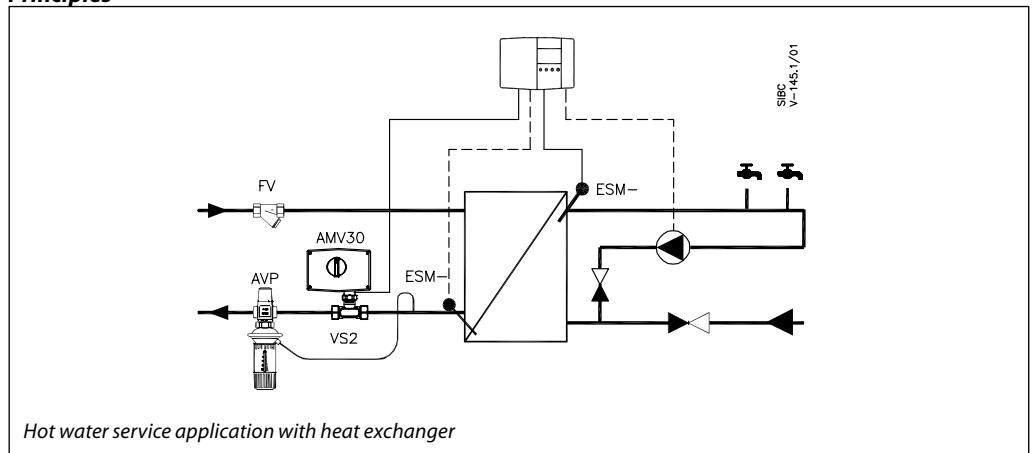

**Ordering**

DN	Ext. thread ISO 228/1	$k_{vs}$ (m <sup>3</sup> /h)	Stroke (mm)	Code No.
15	G ¾ A	0.25	4	<b>065F2111</b>
		0.40	4	<b>065F2112</b>
		0.63	4	<b>065F2113</b>
		1.0	4	<b>065F2114</b>
		1.6	4	<b>065F2115</b>
20	G 1 A	2.5	5	<b>065F2120</b>
25	G 1¼ A	4.0	5	<b>065F2125</b>

**Accessories**

DN	Weld-on tailpieces	Tailpieces with external threads
15	<b>003H6908</b>	<b>003H6902</b>
20	<b>003H6909</b>	<b>003H6903</b>
25	<b>003H6910</b>	<b>003H6904</b>

**Spare parts**

Type	Valve size	Code No.
Stuffing box	DN 15 - 25	<b>065F0006</b>

**Ordering**

Pressure stage	PN 16
Max. water temperature	130 °C
Cavitation factor	≥ 0.5
Max. closing pressure $\Delta p$	10 bar
Max. operating pressure $\Delta p_v$	6 bar *
Control characteristic	Lin for $k_{vs}$ 0.25 - 1.6, split for $k_{vs}$ 2.5 - 4.0
Leakage acc. to standard IEC 534	Max. 0.05% of $k_{vs}$
Control range	> 50:1
Media	Water, pH 7 - 10 Glycolic water 30% down to 5 °C
Thread standard	ISO 228 - 1

\* Increased noise level when  $\Delta p_v$  is higher than 4 bar

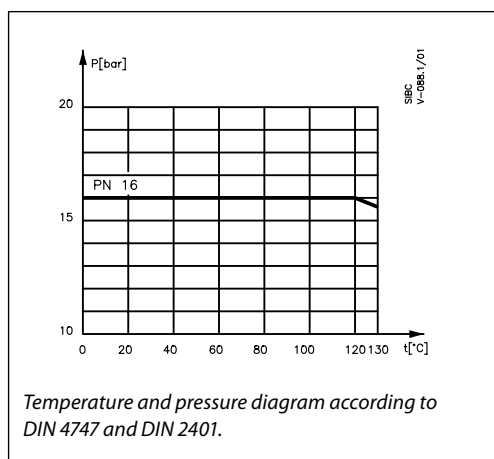
**Materials**

Body	Dezincing free brass
Cone, seat and spindle	Stainless steel
Gasket	EPDM O-rings

Sizing

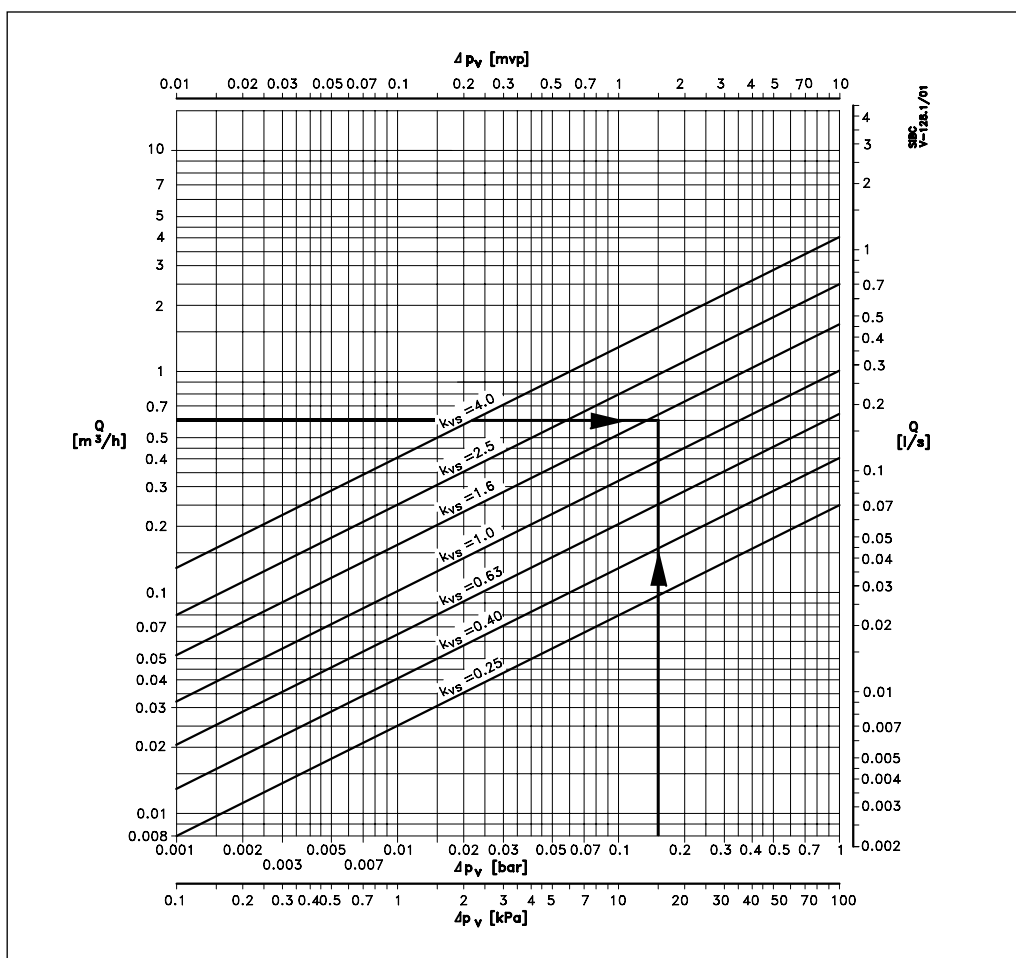

**Example:**

Given:

$P = 14 \text{ kW}$       $P =$  heating power (kW)  
 $\Delta t = 20 \text{ K}$       $\Delta t =$  temperature difference (K)  
 $\Delta P_v = 0.15 \text{ bar}$       $\Delta P_v =$  differential pressure across the valve (bar)

Current flow  $Q$  ( $\text{m}^3/\text{h}$ ) through the valve is calculated according to formula:

$$Q = \frac{P \times 0.86}{\Delta t}$$

$$Q = \frac{14 \times 0.86}{20} = 0.6 \text{ m}^3/\text{h}$$

$k_{vs}$  value - flow ( $\text{m}^3/\text{h}$ ) in fully opened valve is calculated according to formula:

$$k_{vs} = \frac{Q}{\sqrt{\Delta p_v}}$$

$$k_{vs} = \frac{0.6}{\sqrt{0.15}} = 1.5 \rightarrow 1.6 \text{ m}^3/\text{h}$$

or read from sizing diagram by taking a line through  $Q$  scale ( $0.6 \text{ m}^3/\text{h}$ ) and  $\Delta p$  scale ( $0.15 \text{ bar}$ ) to intersect  $k_{vs}$  axis at 1.6.

**Solution:**

VS 2 DN 15  $k_{vs} = 1.6$

Dimensions

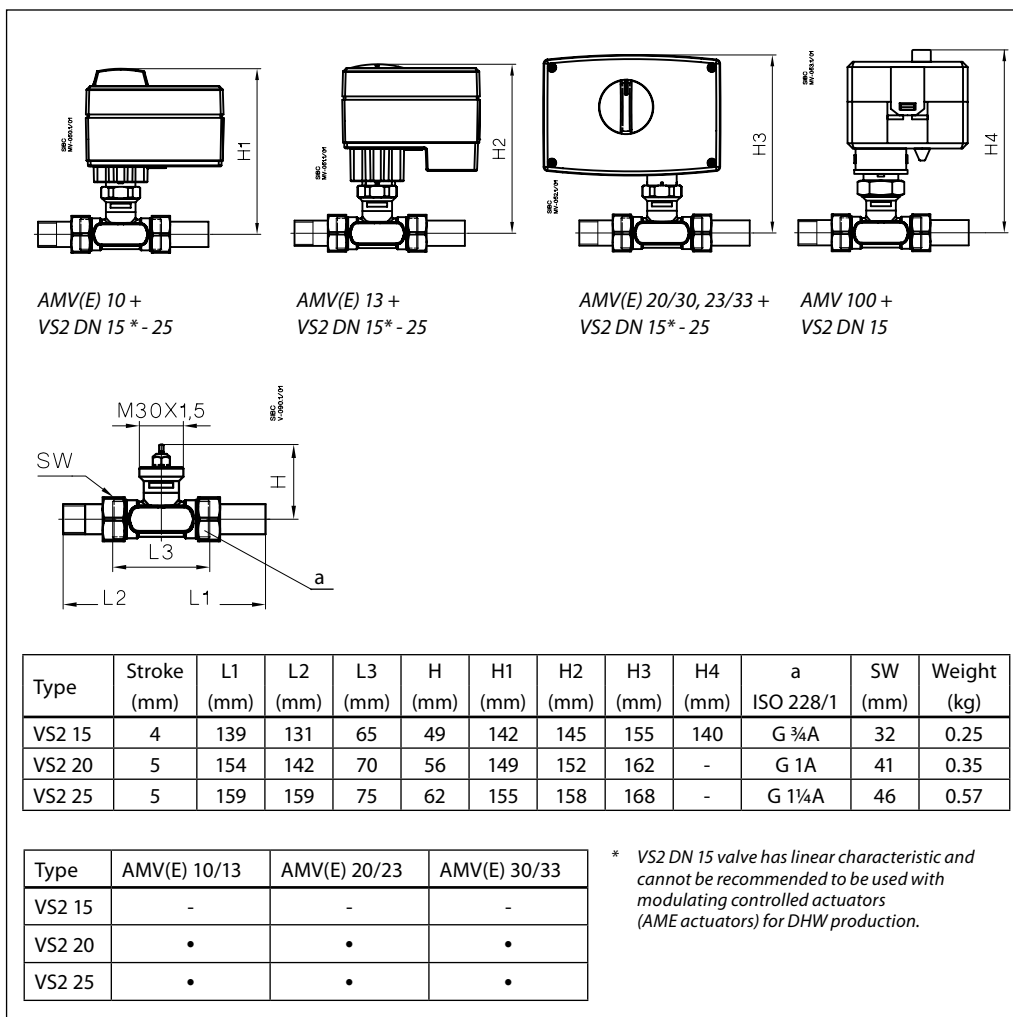

Danfoss can accept no responsibility for possible errors in catalogues, brochures and other printed material. Danfoss reserves the right to alter its products without notice. This also applies to products already on order provided that such alterations can be made without consequential changes being necessary in specifications already agreed. All trademarks in this material are property of the respective companies. Danfoss and the Danfoss logotype are trademarks of Danfoss A/S. All rights reserved.