



KLA Standard

KLA GS

Installation and Operating Instructions

Flap-type Flow Meter

KLA Standard

KLA Standard-IK

KLA Standard-IKS

KLA GS



Kirchner und Tochter



Contents

1. Foreword.....	3
2. Safety.....	3
2.1. Symbol and meaning.....	3
2.2. General safety directions and exemption from liability.....	3
2.3. Intended use	3
2.4. Special safety directions for glass devices.....	4
2.5. Information for Operator and operating personnel	4
2.6. Regulations and guidelines	4
2.7. Notice as required by the hazardous materials directive	4
3. Transport and storage.....	4
4. Installation	4
4.1. Installation KLA.....	5
5. Start-up.....	5
6. Readings in operation.....	5
7. Limit switches.....	5
7.1. Connecting the limit switches.....	6
8. Maintenance and cleaning of the flow meter.....	6
9. Service	6
9.1. Disposal.....	6
10. Technical data	7
10.1. Dimensions.....	8
10.2. Technical data of limit switches.....	9



1. Foreword

These Installation and Operating Instructions are applicable to devices of Series KLA. Please follow all instructions and information given for installation, operation, inspection and maintenance. The Instructions form a component part of the device, and should be kept in an appropriate place accessible to the personnel in the vicinity of the location. Where various plant components are operated together, the operating instructions pertaining to the other devices should also be observed.

2. Safety

2.1. Symbol and meaning



Safety notice

This safety notice can be found at all hints on work safety in these assembly and operating instructions pointing out hazards for life and limb of persons. Such notices should be strictly observed.

2.2. General safety directions and exemption from liability

This document contains basic instructions for the installation, operation, inspection and maintenance of the flap-type flow meter. Failure to comply with these instructions can lead to hazardous situations for Man and Beast and also to damage to property, for which Kirchner und Tochter disclaims all liability.

The Operator is required to rule out potentially hazardous situations through voltage and released media energy.

2.3. Intended use

The KLA Series device is a flap-type VA flow meter for fluids. It is designed for installation in horizontal or vertical pipe runs. In vertical pipe runs, flow through the device must be from below. Installation in the pipeline may only be carried out in accordance with these Instructions. Select the version of the flap-type VA flow meter on the basis of the pipe diameter at the installation location of the device. The limit values for the device are specified in Section 10 and must be complied with. Any modifications or other changes made to the measuring device may be carried out solely by Kirchner und Tochter. Details pertaining to the fluid product and operating conditions are noted on the scale.



2.4. Special safety directions for glass devices



For safety reasons, we recommend placing a protective shield in front of the measuring device before starting up flow meters fitted with glass panels. The devices should not be operated where there is risk of pressure surges!

2.5. Information for Operator and operating personnel

Authorized installation, operating, inspection and maintenance personnel should be suitably qualified for the jobs assigned to them, and should receive appropriate training and instruction. All persons charged with assembly, mounting, operation, inspection and maintenance duties must have read and understood the operating instructions. Gaskets in contact with the fluid product must be replaced after all maintenance and repair work.

2.6. Regulations and guidelines

In addition to the directions given in these Installation and Operating Instructions, observe the regulations, guidelines and standards, such as DIN EN, and, for specific applications, the codes of practice issued by DVGW (gas and water) and VdS (underwriters), or the equivalent national codes, and applicable national accident prevention regulations.

2.7. Notice as required by the hazardous materials directive

In accordance with the law concerning handling of waste (critical waste) and the hazardous materials directive (general duty to protect), we would point out that all flow meters returned to Kirchner und Tochter for repair are required to be free from any and all hazardous substances (alkaline solutions, acids, solvents, etc.).



Make sure that devices are thoroughly rinsed out to neutralize hazardous substances.

3. Transport and storage

The KLA device is packed by the factory in packaging appropriate for transportation and storage. Transport and storage should be carried out solely in the original packaging. Protect the device against rough handling, impact, jolts, etc.

4. Installation

Flap-type flow meters are suitable for installation in either vertical or horizontal pipe runs. In vertical pipe runs, flow must be from bottom to top.

Make sure the pipes are correctly spaced and in true alignment at the installation location for the flow meter. For connection of the KLA device, fit the open ends of the pipeline at the installation point with flanges appropriate to the flow meter.

Straight unimpeded pipe runs upstream and downstream of the meter's installation location should have a length equal to a minimum of 2 x DN. Any control equipment, particularly in the case of gaseous media, should always be located downstream of the flow meter.



4.1. Installation KLA

For mounting, provide the connection flanges of the KLA with suitable flat gaskets. The gaskets are not included with the flow meter.

Before installing, remove the transport lock from inside the device, and fit the open pipe ends with appropriate connecting flanges. Make sure the pipes are in true alignment and the sealing faces spaced correctly. Install the device in the direction of flow indicated by the arrow on the scale such that it is free from stresses. Use gaskets made of rubber, PVC or Teflon.

5. Start-up

The device must have been properly installed before it is started up.

- Test the device connections.
- Setting the flow: pressurize the pipelines by slowly opening the shutoff valves. In the case of liquids, make sure the pipeline is carefully vented.
- Check the leak-tightness of all components and if necessary retighten threaded joints and bolted connections.

6. Readings in operation

On the standard device, values are read off at the pointer on the resopal scale.

On the KLA GS version, the flow rate is indicated directly by the flap. At the front and rear, the flow meter features in each case a pane of hard glass. The flow rate is read off from a scale attached to the front hard glass pane on a level with the top edge of the KLA flap. Measured values are correct only when the operating condition at the measuring point (flowing medium, operating pressure and temperature) corresponds to the operating state data marked on the scale.

7. Limit switches

The flow meter can be equipped with limit switches with preset switching point to provide local indication with monitoring function. The switches have a bistable characteristic.

The following devices are equipped with limit switches:

KLA Standard-IK	with	SJ3,5N
KLA Standard-IKS	with	SB3,5-E2

Uncontrolled current and voltage peaks can occur in the case of inductive or capacitive loads, e.g. from contactors or solenoid valves. Such peaks will also occur, depending on cable geometry, when cables exceed a certain length. We therefore recommend using an MSR contact protection relay, which can be additionally supplied. This will increase the contact rating and prevent the occurrence of inductive and capacitive peaks, thus ensuring long service life of the contacts.

Electrical data and limit values are specified in Section 10.2.



7.1. Connecting the limit switches



- Electrical connection of the device should be carried out in conformity with the relevant VDE regulations (or equivalent national standards) and in compliance with the regulations issued by your local power supply utility.
- Disconnect the system from supply before connecting the limit switch.
- Provide a protective circuit for the switches in keeping with their capacity.
- Connect appropriate fuse-elements on the line side (matched to consumption).
- Connect the cable using the supplied right-angle plug. The circuit diagram for the limit switches is given in the technical data, Section 10.2.

8. Maintenance and cleaning of the flow meter

The flow meter can be opened from the back. Undo the fastening screws on the rear cover and take the cover off. Remove any dirt and deposits that may have accumulated in the casing and on the flap. The shaft of the flap runs on pivot bearings. Should these have too much play, the device can also be opened from the front. Detach the lock nuts and retighten the bearing screws. Then retighten the lock nuts. The flap must be positioned so close to the front plate that, without the seal, it just slightly rubs against this plate. If the seal is then re-inserted before final assembly, the flap will move freely. The pointer must be able to move freely across the resopal plate. Be sure to replace the cover to close the device tightly.

9. Service

All devices with defects or deficiencies should be sent direct to our repair department. To enable our customer service facility to deal with complaints and repairs as quickly as possible, you are kindly requested to coordinate the return of devices with our sales department, Tel. +49 (0) 2065-96090.

9.1. Disposal

Please help to protect our environment, and dispose of workpieces in conformity with current regulations or use them for some other purpose.



10. Technical data

Connection	to DIN 2501 optionally: ASA 150 lbs
Pressure rating	PN 10 (standard) or PN 6 (special version) cast steel: PN25
Fitting dimensions	DN 25 - 200 / 1/2" - 8"
Mounting length	see Table
Corrosion protection	epoxy resin paint, traffic blue RAL 5017, stove-enamelled
Rubber lining	NR-isoprene quality
Thermostability ¹⁾	standard: 100°C with rubber lining: max. 90°C special version: up to max. 250°C
Turndown ratio	normally 1:10
Measurement uncertainty	5% FS
Viewing window	pressed hard glass
Degree of protection	in conformity with IP 54, switches: IP 53

¹⁾ On no account may the fluid product be allowed to freeze

Materials

Type/device	Flap	Bearings	Plate	Blind flanges	Gasket	DN
KLA Standard						
Grey cast iron	1.4571	1.4571	1.4571	Grey cast iron/steel	NBR	15 - 150
Grey cast iron	Rg 5	1.4571	1.4571	Grey cast iron/steel	NBR	32 - 150
Welded steel	Rg 5	1.4571	1.4571	Steel	NBR	200
KLA GS				Ring		
Grey cast iron	1.4571	1.4571	Glass	Steel	NBR	15 - 25
Grey cast iron	Rg 5	1.4571	Glass	Steel	NBR	32 - 150
KLA rubber-lined version				Blind flange		
Grey cast iron, rubber-lined	1.4571	1.4571	1.4571	Grey cast iron/steel, rubber-lined	Sil-C8200	32 - 150
Grey cast iron, rubber-lined	Hastelloy C4	Hastelloy C4	VA-Teflon	Grey cast iron/steel, rubber-lined	Sil-C8200	32 - 150
Grey cast iron, rubber-lined	Teflon	Hastelloy C4	VA-Teflon	Grey cast iron/steel, rubber-lined	Sil-C8200	80 - 150
Grey cast iron, rubber-lined	Teflon	Teflon	VA-Teflon	Grey cast iron/steel, rubber-lined	Sil-C8200	80 - 150

Other gaskets, rubber linings (e.g. with drinking water approval) and coatings with Teflon (HALAR) or cast grades such as steel, SG iron, bronze, VA or Hastelloy as well as RG5 and red brass grades on request



10.1. Dimensions

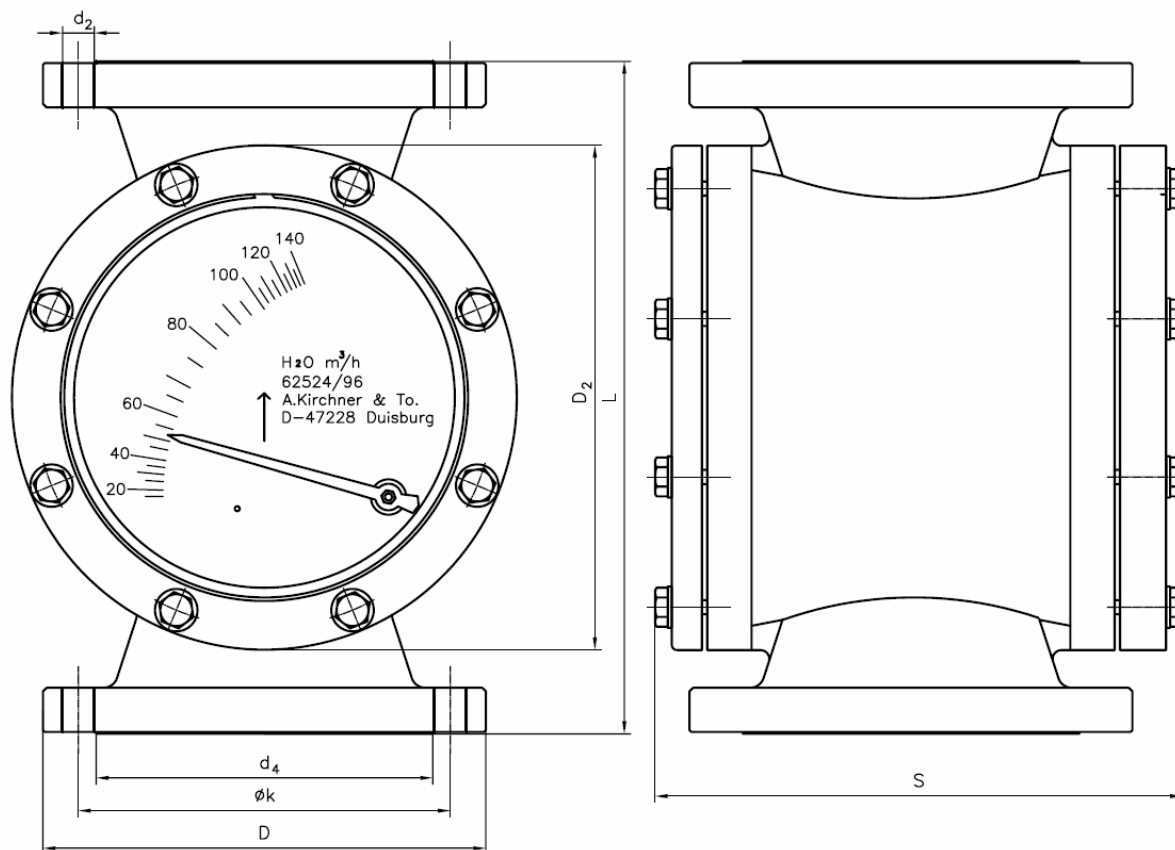

DN	D	d ₄	k	h	Number of bolts	d ₂	L	D ₂	S Standard/GS	Weight [kgs]
15	95	45	65	16	4	M 12	170	119	145/132	8
20	105	58	75	16	4	M 12	170	119	145/132	8,5
25	115	68	85	16	4	Ø 14	170	119	145/132	8,5
32	140	78	100	21	4	Ø 18	240	165	176/186	16
40	150	88	110	21	4	Ø 18	240	165	176/186	16
50	165	102	125	21	4	Ø 18	240	165	176/186	17
65	185	122	145	21	4	Ø 18	280	185	201/217	22
80	200	138	160	22	8	Ø 18	320	225	214/227	34
100	220	158	180	24	8	Ø 18	350	245	267/278	43
125	250	188	210	24	8	Ø 18	380	285	299/310	58
150	285	212	240	24	8	Ø 22	380	295	299/310	64
200	340	268	295	27	8	Ø 22	550	370	386/-	104

All dimensions in mm



10.2. Technical data of limit switches

The following devices are equipped with limit switches:

KLA Standard-IK with SJ3,5N
 KLA Standard-IKS with SB3,5 E2

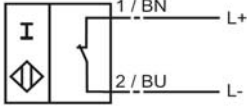
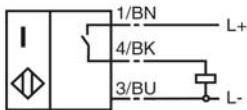
Inductive limit switches		
Designation	SJ3,5 N	SB3,5 E2
Properties	adjustable, bistable	adjustable, bistable
Switching function	NAMUR NC contact	NO contact
Voltage switched (max.)	8 V DC	10 - 30 V DC
Temperature limits	-25°C to 100°C	-25°C to 70°C
Explosion protection	with KFAEx1	
Circuit diagram	N / NO 	E2 
Pin assignment:		
	1 2/BU	3/BU
	2 1/BN	1/BN
	3 unassigned	4/BK
	PE unassigned	unassigned

Connection via right-angle plug (pole number: 3 + PE) to DIN 46350, model A, with screwed cable gland M16 (IP65)



The equipment from Kirchner und Tochter has been tested in compliance with the applicable CE-regulations of the European Community. The respective declaration of conformity is available on request. The Kirchner und Tochter QM-System will be certified in accordance with DIN-EN-ISO 9001:2000. The quality is systematically adapted to the increasing demands.



Kirchner und Tochter